



DF140 Heavy Fuel UAV Engine



- **Liquid Cooled**
- **8.6 kW**
- **JP8 / JP5 / Jet A1**
- **Gasoline**
- **Four Cylinder**
- **Fuel Injection**
- **4 Stroke**

RCV Engines Ltd has a range of multi-fuel UAV engines that can operate equally well on gasoline or heavy fuel. The RCV combustion system is based on a unique patented revolving valve, that generates a high level of turbulence for good mixture preparation and creates an ideal compact combustion chamber for heavy fuel operation.

- Four-stroke cycle for low emissions and fuel consumption
- Liquid cooling enables enclosed engine installation
- Large valve area gives high power with a wide power band
- Reliable combustion and power on heavy fuel from 8:1 to 15:1 AFR
- Excellent starting over a wide temperature range -20°C to +55°C
- Resistant to detonation – heavy fuel operation without de-rating
- No combustion chamber hot spots – minimising carbon build up
- High reliability, low maintenance with long MTBO:
 - No injectors in the combustion chamber to carbon up
 - No valve clearances to adjust
 - Shielded spark plug for minimum plug fouling and long life
- Designed as a UAV engine not modified from a hobby engine
 - Electronic fuel injection system with altitude compensation
 - Dedicated mounting system for 100 W to 3 kW alternators
- For further details see www.rcvengines.com/technology

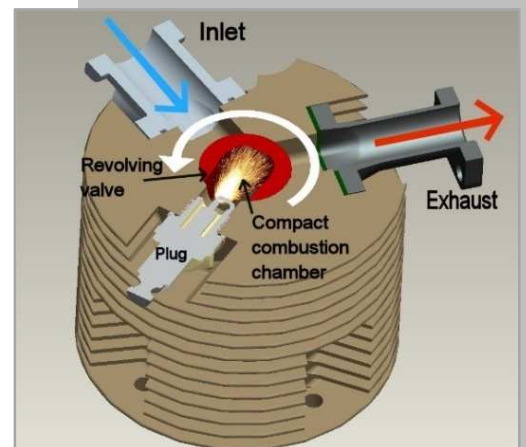

Specification

Standard Build	DF140LC
Type	140 cc Four cylinder
Power (JP8)	8.61 kW (11.5 hp) at 8800 rpm
Weight Complete*	4.8 Kg (10.6 lb)
Combustion System	Revolving valve, 4-stroke
Cooling / Lubrication	Liquid cooling / Oil in fuel 1:25
Fuelling	Low pressure manifold injection with altitude compensation
Heavy Fuel Starting	Cold start assisted with installed cartridge heaters
Fuel Consumption (JP8)	330 g/kW.hr (0.54 lb/hp.hr)
TBO	250 hrs (VTOL), 500 hrs (Fixed Wing)
Options	
Rotation	Clockwise or Anti-Clockwise viewing the prop drive
Starting	Starter Generator
Cooling	Custom Radiator Design

*Weight includes engine assembly ready to run with fuel system, ECU, wiring and exhaust. Weight does not include prop, generator or cowling.

For further details see www.rcvengines.com/unmanned-vehicle-engines

Typical Dimensions (mm)

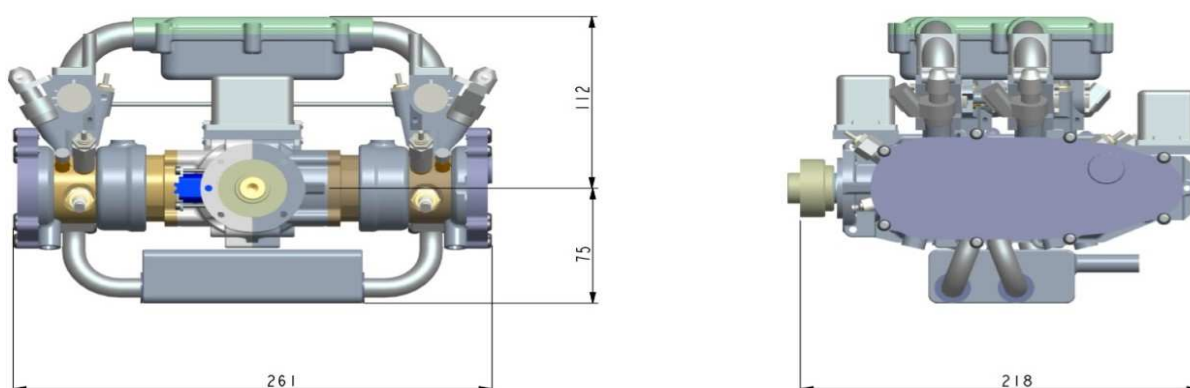

Applications

- Fixed wing
- Helicopter - Rotary Wing
- Hybrid
- Marine
- Portable power



Fixed Wing UAV



Marine Hybrid with Water Cooling

Enquiries

RCV Engines has complete design control and as such can either supply an existing unit or configure an engine for a specific platform or application. Subject to establishing confidentiality arrangements 3D CAD data can be made available for installation studies. RCV can also evaluate which engine is the most suitable for a specific application.

Production engines are available from RCV Engines. Arrangement for licensed manufacture and/or production supply from an RCV Engines partner company.

For all enquiries contact: info@rcvengines.com